

THERMOPILE SPECIFICATION

1. Scope

This specification defines ratings, characteristics, reliability and dimensions for this thermopile.

2. Part No.

10TP583T-0154

3. Ratings

1)THERMOPILE



Item	Characteristics	Condition
Output Voltage 1	180 $\mu V \pm 30\%$ $\triangle 200$	Blackbody Temperature: 500K Aperture size: $\phi 12.7\text{mm}$ Sensor – Blackbody Distance: 100mm Thermopile Temperature: 298K
Output Voltage 2	0.9 $mV \pm 30\%$ $\triangle 1.0$	Blackbody Temperature: 37°C Thermopile Temperature: 25°C (Standard test Method by Ishizuka.)
Thermopile Resistance	$65k \Omega \pm 30\%$	At 25°C
Operating Temperature Range	$-20 \sim 100^\circ\text{C}$	
Storage Temperature Range	$-40 \sim 100^\circ\text{C}$	
Insulation Resistance	$\geq 500M \Omega$	Apply DC25V between terminal 3 and 4 under condition of short circuit terminal 1 and 3. (cf. 6.Dimensions)

2)THERMISTOR

Item	Characteristics	Condition
Nominal Zero – power Resistance Value (R_{25})	$100k \Omega \pm 3\%$	At 25°C
B – Value ($B_{25/85}$)	$3435K \pm 0.7\%$ $B_{25/85}$: Tolerance in a lot is $\pm 0.2\%$.	Calculated using the zero-power resistance values measured at 25°C and 85°C.

\triangle ※Thermistor element shall be inspected by following standard.

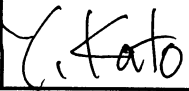
Utilized Standard : ANSI/ASQC Z1.4 Standard Inspection Level ,
Method of two times normal sampling, AQL 0.40%.

Spec.No : S02-0154D		Note	REVISION	
Date : June. 18,2002			A	August 9,2002 Complete revision
Approved	Checked	Drawn	B	January 21,2003 delete and addition
		<i>m. usui</i>	C	Feburary 6,2003 delete and addition
			D	November 10,2003 delete and addition

4.Characteristics

1) Output Voltage vs. Object Temperature

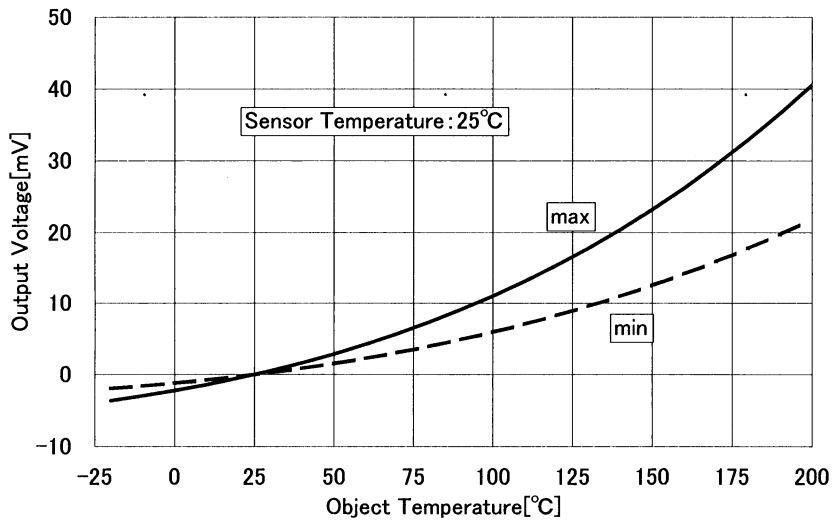

2) Typical Field of View (Typical)

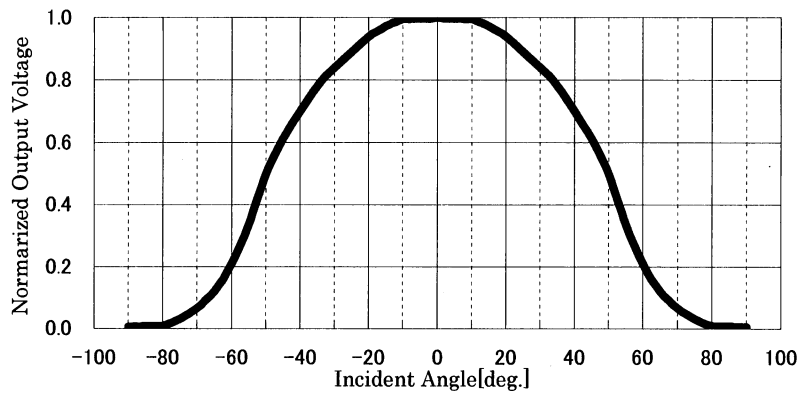

3) Typical Filter Range (Typical)

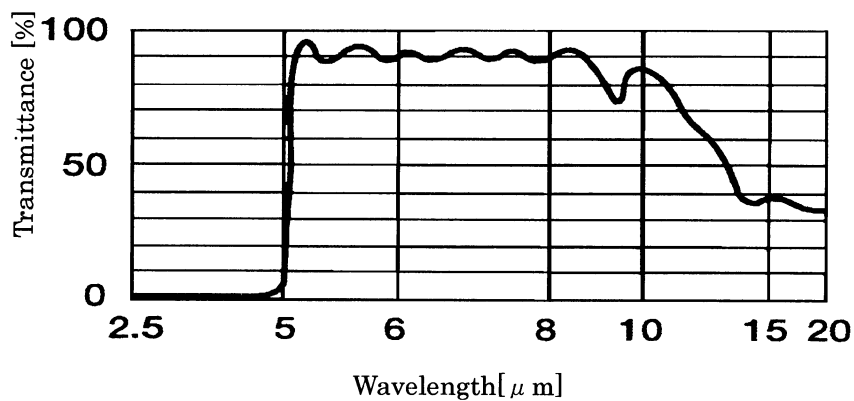

5. Properties

1) Mechanical Properties

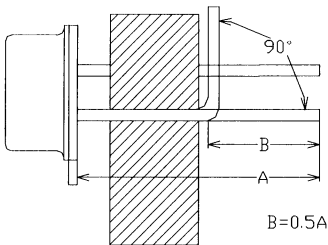
Items	Conditions	Criteria
Free fall	Drop samples 3times naturally onto concrete from 1m high.	The change ratio of Output Voltage of Thermopile shall be within $\pm 2\%$ of initial value. The change ratio of Resistance(R_{25}) of Thermistor shall be $\pm 0.3\%$ of initial value. The change ratio of B-value($B_{25/85}$) of Thermistor shall be $\pm 0.2\%$ of initial value.
Vibration	After the following vibration is applied to test samples for 2 hours, Direction: X.Y.Z Peak to peak amplitude: 1.5mm Frequency: 10Hz→55Hz→10Hz (Time of one cycle :1 minute)	The change ratio of Output Voltage of Thermopile shall be within $\pm 2\%$ of initial value. The change ratio of Resistance(R_{25}) of Thermistor shall be $\pm 0.3\%$ of initial value. The change ratio of B-value($B_{25/85}$) of Thermistor shall be $\pm 0.2\%$ of initial value.
Bending	Fix sample vertically. Bending cycling shall be repeated 2.5 times. One cycling shall be as follows: Bend into 90° →Bend back to original position. 	Lead wire shall not be snapped off.
Resistance to soldering heat	Apply 350°C \pm 10°C, 5 \pm 1sec. to leads.	The change ratio of Output Voltage of Thermopile shall be within $\pm 2\%$ of initial value. The change ratio of Resistance(R_{25}) of Thermistor shall be $\pm 0.3\%$ of initial value. The change ratio of B-value($B_{25/85}$) of Thermistor shall be $\pm 0.2\%$ of initial value.

2) Climatic properties

Items	Conditions	Criteria
Dry heat	At 60°C ± 5°C, 1 000hr.	The change ratio of Output Voltage of Thermopile shall be within ±2% of initial value. The change ratio of Resistance(R ₂₅) of Thermistor shall be ±0.3% of initial value. The change ratio of B-value(B _{25/85}) of Thermistor shall be ±0.2% of initial value.
	At 100°C ± 5°C, 1 000hr.	The change ratio of Output Voltage of Thermopile shall be within ±2% of initial value. The change ratio of Resistance(R ₂₅) of Thermistor shall be ±0.5% of initial value. The change ratio of B-value(B _{25/85}) of Thermistor shall be ±0.2% of initial value.
Cold	At -40°C ± 5°C, 1 000hr.	The change ratio of Output Voltage of Thermopile shall be within ±2% of initial value. The change ratio of Resistance(R ₂₅) of Thermistor shall be ±0.3% of initial value. The change ratio of B-value(B _{25/85}) of Thermistor shall be ±0.2% of initial value.
Temperature cycling	Temperature cycling shall be repeated 10 times. One cycle shall be as follows: At -20°C ± 5°C for 30min. → At 25°C ± 5°C for 3min. → At 100°C ± 5°C for 30min. → At 25°C ± 5°C for 3min.	The change ratio of Output Voltage of Thermopile shall be within ±2% of initial value. The change ratio of Resistance(R ₂₅) of Thermistor shall be ±0.3% of initial value. The change ratio of B-value(B _{25/85}) of Thermistor shall be ±0.2% of initial value.
Damp heat	At 60°C ± 5°C, At 85% ± 5%RH, 1 000hr.	The change ratio of Output Voltage of Thermopile shall be within ±2% of initial value. The change ratio of Resistance(R ₂₅) of Thermistor shall be ±0.3% of initial value. The change ratio of B-value(B _{25/85}) of Thermistor shall be ±0.2% of initial value.

6. Dimensions

Unit:[mm]

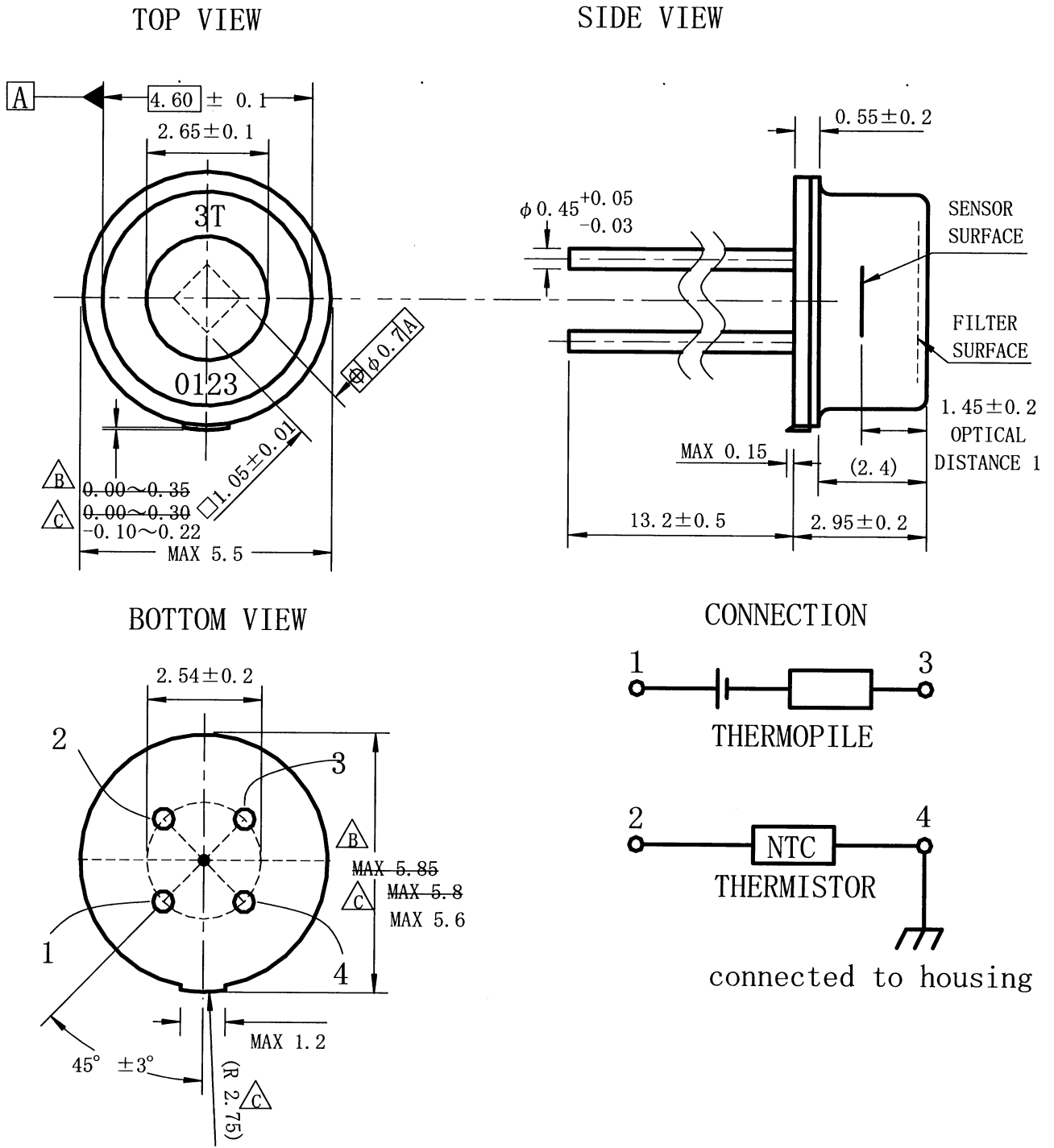

Marking(example) : 3T
0123

①: "3T" represents Part No. of 10TP583T-0154
②: "0123" represents Lot No

7. Packaging method

1) Material and dimension of the stick magazine.

Material: Transparent polystyrene (Antistatic treated)

Dimension: $277 \pm 1\text{mm} \times 7.3 \pm 0.3\text{mm} \times 19.2 \pm 0.3\text{mm}$

Markingcolor:Red

Unit:[mm]

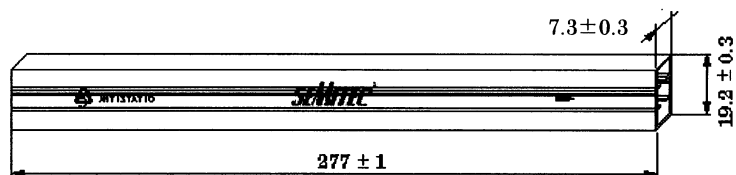

2) Stick Magazine

Stoppers shall be inserted into both ends of the stick magazine.

Quantity: 50pcs per stick magazine.

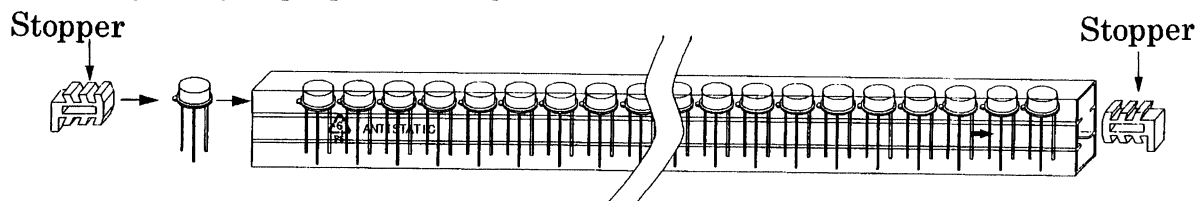

3) Internal box

Dimension: $307\text{mm} \times 90\text{mm} \times 45\text{mm}$

Quantity: 1000pcs per internal box.

Stick Magazines are put into a plastic bag, which bag is vacuumed and sealed.

Marking side of the magazine shall face to the same direction.

A desiccant is also put into the plastic bag.

This plastic bag is enclosed into an internal box.

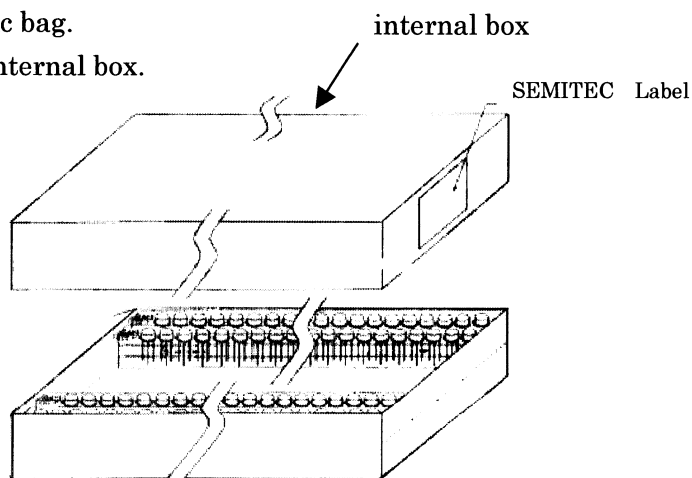

8. Output Voltage characteristics (Typical)

Thermopile Output Voltage [mV]		Thermistor Temperature[°C]												
		-20	-10	0	10	20	30	40	50	60	70	80	90	100
Object Temperature [°C]	-20	0.00	-0.51	-1.08	-1.71	-2.42	-3.20	-4.07	-5.02	-6.06	-7.20	-8.45	-9.81	-11.28
	-10	0.51	0.00	-0.57	-1.20	-1.91	-2.69	-3.56	-4.51	-5.55	-6.69	-7.94	-9.30	-10.77
	0	1.08	0.57	0.00	-0.64	-1.34	-2.12	-2.99	-3.94	-4.98	-6.13	-7.37	-8.73	-10.20
	10	1.71	1.20	0.64	0.00	-0.71	-1.49	-2.35	-3.30	-4.35	-5.49	-6.74	-8.09	-9.57
	20	2.42	1.91	1.34	0.71	0.00	-0.78	-1.65	-2.60	-3.64	-4.78	-6.03	-7.39	-8.86
	30	3.20	2.69	2.12	1.49	0.78	0.00	-0.86	-1.82	-2.86	-4.00	-5.25	-6.60	-8.08
	40	4.07	3.56	2.99	2.35	1.65	0.86	0.00	-0.95	-1.99	-3.14	-4.38	-5.74	-7.21
	50	5.02	4.51	3.94	3.30	2.60	1.82	0.95	0.00	-1.04	-2.19	-3.43	-4.79	-6.26
	60	6.06	5.55	4.98	4.35	3.64	2.86	1.99	1.04	0.00	-1.14	-2.39	-3.74	-5.22
	70	7.20	6.69	6.13	5.49	4.78	4.00	3.14	2.19	1.14	0.00	-1.25	-2.60	-4.08
	80	8.45	7.94	7.37	6.74	6.03	5.25	4.38	3.43	2.39	1.25	0.00	-1.36	-2.83
	90	9.81	9.30	8.73	8.09	7.39	6.60	5.74	4.79	3.74	2.60	1.36	0.00	-1.47
	100	11.28	10.77	10.20	9.57	8.86	8.08	7.21	6.26	5.22	4.08	2.83	1.47	0.00
	110	12.88	12.37	11.80	11.16	10.46	9.67	8.81	7.86	6.81	5.67	4.43	3.07	1.60
	120	14.60	14.09	13.52	12.89	12.18	11.40	10.54	9.58	8.54	7.40	6.15	4.80	3.32
	130	16.47	15.96	15.39	14.75	14.05	13.26	12.40	11.45	10.41	9.26	8.02	6.66	5.19
	140	18.47	17.97	17.40	16.76	16.05	15.27	14.41	13.46	12.41	11.27	10.02	8.67	7.19
	150	20.63	20.12	19.56	18.92	18.21	17.43	16.57	15.62	14.57	13.43	12.18	10.83	9.35
	160	22.95	22.44	21.87	21.24	20.53	19.75	18.88	17.93	16.89	15.75	14.50	13.14	11.67
	170	25.43	24.93	24.36	23.72	23.01	22.23	21.37	20.42	19.37	18.23	16.98	15.63	14.15
180	28.09	27.58	27.01	26.38	25.67	24.89	24.02	23.07	22.03	20.89	19.64	18.29	16.81	
190	30.93	29.85	29.85	29.85	29.85	29.85	29.85	29.85	29.85	29.85	29.85	29.85	29.85	
200	33.96	33.45	32.88	32.25	31.54	30.76	29.89	28.94	27.90	26.76	25.51	24.15	22.68	

9. Temperature vs. Resistance of Thermistor [ITS-90]

(R_{25} :100k Ω \pm 3%、 $B_{25/85}$: 3435K \pm 0.7%)

1)

Temp.(°C)	Rmax. (k Ω)	Rst. (k Ω)	Rmin. (k Ω)	Tolerance(°C)	
-20	706.14	676.46	647.44	---	0.91
-19	672.49	644.45	617.01	-0.88	0.91
-18	640.70	614.18	588.24	-0.88	0.91
-17	610.64	585.56	561.01	-0.88	0.91
-16	582.20	558.48	535.24	-0.88	0.91
-15	555.30	532.85	510.84	-0.88	0.91
-14	529.83	508.58	487.73	-0.88	0.91
-13	505.71	485.58	465.83	-0.88	0.91
-12	482.87	463.80	445.08	-0.88	0.91
-11	461.21	443.14	425.39	-0.88	0.91
-10	440.69	423.55	406.71	-0.88	0.89
-9	420.91	404.67	388.71	-0.87	0.89
-8	402.16	386.77	371.63	-0.87	0.89
-7	384.38	369.79	355.42	-0.87	0.89
-6	367.51	353.67	340.04	-0.87	0.89
-5	351.50	338.36	325.42	-0.87	0.89
-4	336.29	323.82	311.54	-0.87	0.89
-3	321.85	310.01	298.34	-0.87	0.89
-2	308.13	296.89	285.79	-0.86	0.89
-1	295.09	284.41	273.86	-0.86	0.89
0	282.69	272.54	262.51	-0.86	0.88
1	270.72	261.07	251.54	-0.85	0.88
2	259.33	250.17	241.11	-0.85	0.88
3	248.50	239.79	231.18	-0.85	0.87
4	238.20	229.92	221.73	-0.85	0.87
5	228.39	220.52	212.72	-0.84	0.87
6	218.99	211.50	204.08	-0.84	0.87
7	210.04	202.91	195.85	-0.84	0.87
8	201.51	194.73	188.01	-0.84	0.86
9	193.39	186.94	180.54	-0.84	0.86
10	185.65	179.50	173.41	-0.83	0.86
11	178.21	172.36	166.55	-0.83	0.85
12	171.11	165.54	160.01	-0.83	0.85
13	164.35	159.04	153.77	-0.82	0.85
14	157.89	152.84	147.81	-0.82	0.85
15	151.73	146.92	142.13	-0.82	0.84
16	145.81	141.22	136.66	-0.81	0.84
17	140.16	135.79	131.43	-0.81	0.84
18	134.77	130.60	126.44	-0.81	0.84
19	129.61	125.64	121.67	-0.81	0.84
20	124.69	120.90	117.12	-0.81	0.83

2)

<u>Temp.(°C)</u>	<u>Rmax. (kΩ)</u>	<u>Rst. (kΩ)</u>	<u>Rmin. (kΩ)</u>	<u>Tolerance(°C)</u>	
20	124.69	120.90	117.12	-0.81	0.83
21	119.95	116.34	112.73	-0.80	0.83
22	115.42	111.97	108.53	-0.80	0.83
23	111.10	107.80	104.51	-0.80	0.83
24	106.96	103.82	100.67	-0.80	0.82
25	103.00	100.00	97.000	-0.79	0.82
26	99.245	96.329	93.415	-0.80	0.83
27	95.650	92.816	89.985	-0.82	0.84
28	92.209	89.453	86.702	-0.83	0.86
29	88.912	86.233	83.560	-0.84	0.87
30	85.755	83.149	80.551	-0.85	0.87
31	82.703	80.170	77.645	-0.86	0.89
32	79.779	77.316	74.862	-0.87	0.90
33	76.977	74.582	72.196	-0.88	0.91
34	74.290	71.960	69.641	-0.90	0.93
35	71.714	69.448	67.192	-0.91	0.93
36	69.230	67.025	64.833	-0.92	0.95
37	66.847	64.703	62.570	-0.93	0.96
38	64.561	62.474	60.401	-0.94	0.97
39	62.367	60.336	58.320	-0.96	0.99
40	60.260	58.285	56.323	-0.97	0.99
41	58.223	56.300	54.392	-0.97	1.01
42	56.266	54.395	52.539	-0.99	1.02
43	54.387	52.566	50.760	-1.00	1.03
44	52.582	50.809	49.052	-1.01	1.05
45	50.848	49.122	47.412	-1.03	1.06
46	49.181	47.501	45.836	-1.04	1.07
47	47.579	45.943	44.322	-1.05	1.09
48	46.039	44.445	42.867	-1.07	1.10
49	44.557	43.005	41.469	-1.08	1.12
50	43.132	41.620	40.124	-1.09	1.12
51	41.746	40.273	38.817	-1.10	1.13
52	40.412	38.977	37.560	-1.11	1.15
53	39.129	37.731	36.350	-1.12	1.16
54	37.894	36.532	35.187	-1.14	1.17
55	36.705	35.378	34.068	-1.15	1.19
56	35.561	34.267	32.991	-1.17	1.20
57	34.459	33.198	31.954	-1.18	1.22
58	33.397	32.168	30.956	-1.19	1.23
59	32.374	31.175	29.994	-1.21	1.25

3)

<u>Temp.(°C)</u>	<u>Rmax. (kΩ)</u>	<u>Rst. (kΩ)</u>	<u>Rmin. (kΩ)</u>	<u>Tolerance(°C)</u>	
60	31.388	30.220	29.068	-1.22	1.25
61	30.429	29.290	28.168	-1.23	1.26
62	29.505	28.394	27.301	-1.24	1.28
63	28.614	27.531	26.465	-1.25	1.29
64	27.756	26.699	25.660	-1.27	1.31
65	26.927	25.897	24.884	-1.28	1.32
66	26.129	25.123	24.135	-1.30	1.34
67	25.358	24.377	23.413	-1.31	1.35
68	24.614	23.658	22.717	-1.33	1.37
69	23.897	22.963	22.046	-1.34	1.38
70	23.204	22.293	21.398	-1.35	1.38
71	22.529	21.640	20.767	-1.36	1.40
72	21.878	21.010	20.158	-1.37	1.42
73	21.249	20.402	19.571	-1.39	1.43
74	20.642	19.815	19.004	-1.40	1.45
75	20.055	19.247	18.456	-1.42	1.46
76	19.488	18.700	17.927	-1.43	1.48
77	18.940	18.170	17.416	-1.45	1.49
78	18.411	17.659	16.923	-1.46	1.51
79	17.899	17.165	16.446	-1.48	1.52
80	17.405	16.687	15.985	-1.49	1.53
81	16.924	16.223	15.537	-1.50	1.55
82	16.458	15.774	15.104	-1.52	1.56
83	16.008	15.340	14.685	-1.53	1.58
84	15.573	14.920	14.281	-1.55	1.59
85	15.152	14.513	13.889	-1.56	1.60
86	14.744	14.119	13.509	-1.57	1.62
87	14.348	13.738	13.142	-1.59	1.64
88	13.965	13.369	12.787	-1.61	1.65
89	13.595	13.012	12.443	-1.62	1.67
90	13.236	12.666	12.110	-1.63	1.68
91	12.887	12.330	11.786	-1.64	1.69
92	12.549	12.004	11.472	-1.66	1.71
93	12.222	11.689	11.169	-1.68	1.73
94	11.904	11.383	10.875	-1.69	1.74
95	11.597	11.087	10.590	-1.71	1.76
96	11.299	10.801	10.315	-1.72	1.78
97	11.011	10.523	10.047	-1.74	1.79
98	10.731	10.254	9.7887	-1.76	1.81
99	10.460	9.993	9.5379	-1.77	1.83

10. Precautions for Use of Thermopile Sensor

Warning: Since breakdown of thermopile, and damage or malfunction of used equipment may be caused, comply with the followings:

- (1) Thermopile is designed to match the specified usage. Do not apply unspecified usage.
- (2) When designing equipment, perform reliability test to confirm no abnormality after mounting thermopile.
- (3) Do not use without specified operating temperatures.
- (4) When using thermopile as a sensor, take through measures to prevent accident such as setting safety circuit or using the sensor with equivalent function sensor.
- (5) Please perform the following actions under the environment being affected by noise.
 - Settlement of the protect circuit
 - Shield the whole part of thermopile. (including lead wire)
- (6) Do not use with power more than the ratings or maximum tolerance.
- (7) Do not apply the voltage that is over 5V to Thermopile and Thermistor
- (8) Please do not add vibration, impact shock (falling etc) and pressure which are over the limit to the thermopile.
- (9) Do not fold lead wires at the base of stem
- (10) Please do not add equal to or more than 5N pulling power for the pulling direction to the read wire.
- (11) Please confirm the connecting finish under the clean condition without any dirty, rust for the connecting part of the lead wire to avoid the loose connection.
- (12) Melt solder and soldering iron should only be contacted to the part of the lead wire.
- (13) Soldering condition shall be equal to or less than 10 sec. when the soldering iron is under the condition of 260°C.
- (14) Do not keep using the thermopile for a long time at relative humidities of above 85%.
- (15) Do not use Thermopile under the condensing environment.
- (16) Warn to consumer not to touch thermopile if thermopile can be physical contacted at the final applications.
- (17) Please do not use the thermopile under the following environment.
 - Corrosive gas (Cl₂, NH₃, SO_x, NO_x etc)
 - High conductive conditions (electrolyte, water, salt water)
 - Under a lot of powder dust
- (18) Flux for soldering may cause corrosion. To prevent corrosion, use rosinous flux contains chlorine less than 0.2wt% and wash flux away well after soldering.

Note: When using thermopile, observe the followings:

- (1) Consult with us when you reprocess thermopile.
- (2) When mounting thermopile on equipment, comply with the followings, otherwise, correct "Power of IR" can not be detected and malfunction may occur:
 - Field of view of thermopile shall cover all detecting area.
 - IR transmitted filter shall be clean, with no dew condensation, dirt and scratches.
 - When using optical parts with thermopile, consider well following factors of optical parts:
 - * Transmittance,
 - * Reflectance,
 - * Absorptance
 - * Temperature distribution
 - Thermistor for temperature compensation shall be mounted to thermopile by grease or adhesive with good heat conduction.
- (3) When mounting thermopile by pushing, pressing, tightening or inserting, consult with us as to mounting condition such as mechanical strength.
- (4) Use ethanol for washing thermopile.
- (5) In order to prevent corrosion/deterioration and damage, store Thermopile as packed without load applied at temperature from -10°C to $+40^{\circ}\text{C}$ and relative humidity not exceeding 75% and avoid drastic temperature change, direct sunlight, corrosive gas, dust and dirt. Portion of cross-sectional surface in Nose-Cut and welding area of flange shall not be covered by warranty of rust.
- (6) Portion of cross-sectional surface in Nose-Cut and welding area of flange shall not be covered by warranty of rust.